

Litestak® Status Indicator

Models LSL



NOTIFY STATUS CHANGES WITH COLOR AND SOUND

- Available in 24VDC, 120VAC and 240VAC
- Five lens colors
- Surface mount and integrated 3/4-inch NPT pipe mount
- Indoor use only
- Type 1 enclosure
- Optional sounder available
- UL and cUL Listed and CSA Certified

Federal Signal's Litestak® status indicator is a column of signal lights that indicate the status of a process or machine. The units may include up to five Light Modules (Model LSL) available in Amber, Blue, Clear, Green and Red; or four light modules plus an optional Sound Module (Models LSS or LSH) to create a dual purpose audible/visual status indicator. The Sound Module always occupies the top position of a Litestak unit.

Litestak's lensing provides a 360° visual signal. Individual light modules may be set to either flash or burn steadily. The flasher is included with the 120VAC LSB model and sold separately for other voltages.

Each light module consists of two impact-resistant polycarbonate lens halves that snap apart to provide easy maintenance and interchangeability of colors.

Litestak units can be installed on a 3/4" NPT pipe mount or surface mounted with the Model LSB Base. If low profile surface mounting is required, Model LSBS is available.

Litestak is UL and cUL Listed, and CSA Certified for indoor use.

Multiple lens colors can communicate machine shutdown, shortage of materials, supervisor attention, etc. Ideal applications for the Litestak include assembly lines, instrument panels, workcells, etc. Federal Signal's Litestak is an economical device for increasing productivity in any manufacturing environment.

Model	Voltage	Operating Current	Flash Rate/ Minute	Candela	Mount
LSB-024-120 ¹	24-240VAC/DC	N/A	N/A	N/A	3/4" NPT Pipe/Surface
LSB-120 ¹	120VAC 50/60Hz	N/A	70	N/A	3/4" NPT Pipe/Surface
LSBS ¹	24-240VAC/DC	N/A	N/A	N/A	Low Profile Surface
LSL-024 ²	24VDC	0.76 amps	N/A	123	N/A
LSL-120 ²	120VAC 50/60Hz	0.13 amps	N/A	123	N/A
LSL-240 ²	240VAC 50/60Hz	0.11 amps	N/A	123	N/A

¹ Cap kit included.

² Model LSL includes lens, lamp and light module.



LITESTAK® LIGHT (LSL) AND BASE (LSB)

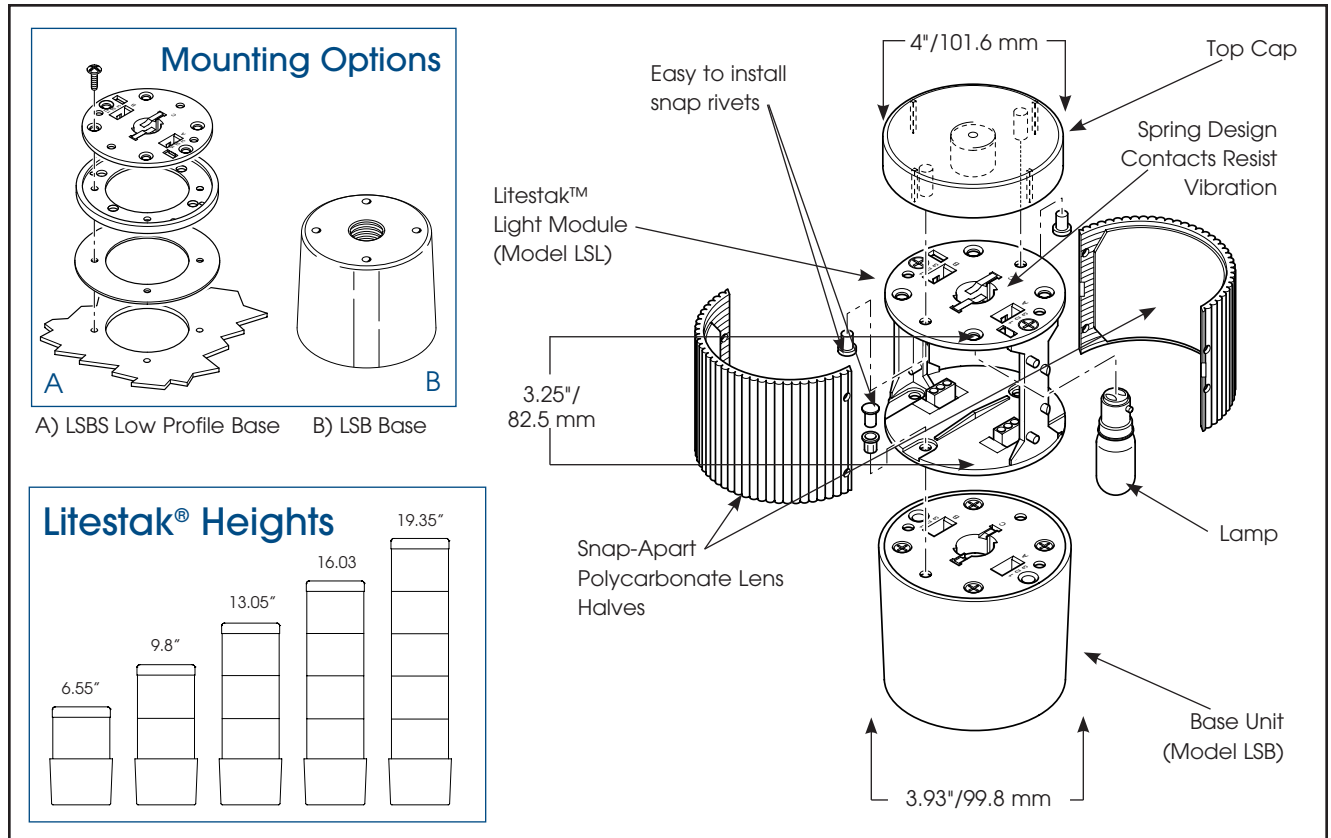

SPECIFICATIONS

Lamp Life:		7,000 Hours	7,000 Hours
Light Source:		Incandescent	Incandescent
Operating Temperature:		0°F to 120°F	-18°C to 49°C
Net Weight:	LSL	0.5 lbs.	0.2 kg
	LSB	0.75 lbs.	0.3 kg
Shipping Weight:	LSL	0.8 lbs.	0.4 kg
	LSB	1.0 lbs.	0.4 kg
Height:	LSL	3.25"	82.5 mm
	LSB	3.3"	82.8 mm
Diameter:	LSL	3.93"	99.8 mm
	LSB	3.93"	99.8 mm

HOW TO ORDER

- Light modules and base modules are ordered separately
- Specify model and voltage of base unit
- Specify model, voltage and colors of light modules
- Specify optional sound module (page 24 & 26)
- Please refer to Model Number Index LSL/LSB beginning on page 368

REPLACEMENT PARTS

<i>Description</i>	<i>Part Number</i>	<i>Description</i>	<i>Part Number</i>
Lens Kit, Amber	K8447014A-02	Lamp, 24VDC	K8107210A
Lens Kit, Blue	K8447014A-04	Lamp, 120VAC	K8107194A
Lens Kit, Clear	K8447014A-05	Lamp, 240VAC	K8107A149A
Lens Kit, Green	K8447014A-01	Flasher, 24VDC	K8285237A
Lens Kit, Red	K8447014A-03	Flasher, 120VAC	K8285239A
Lens Kit, Blackout (1/2 lens)	K8447014A-06	Cap Kit-Snap Rivets included	K8447009E
Snap Rivets, 25 pieces	K7099A112A-01		